

EARTH TERMINALS PROTECTION TERMINALS

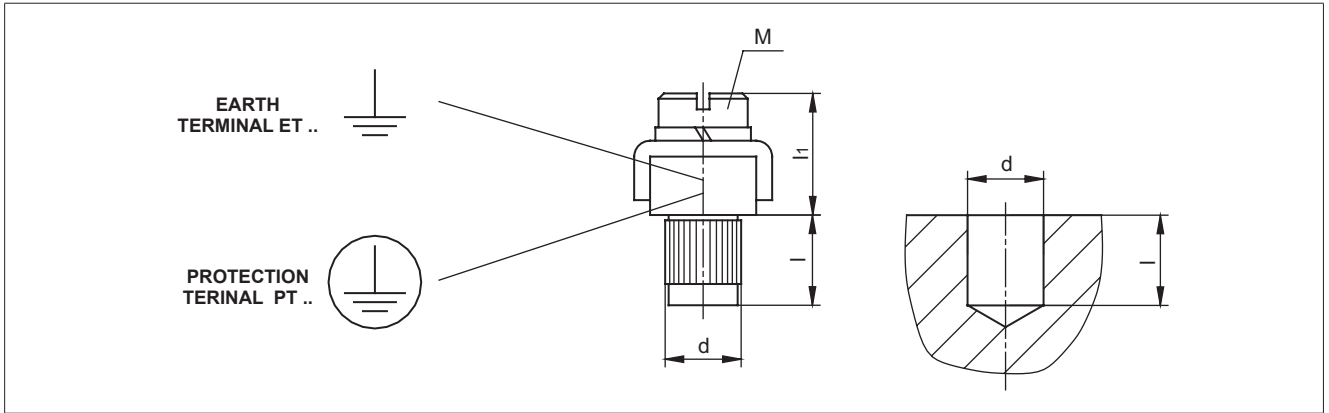

TYPE OF TERMINAL	MARK	CABLE CROSS SECTION [MM ²]		MAX. WIRE DIAMETER [MM]	l [MM]	l ₁ [MM]	d [MM]	MATERIAL	HOLES DIMENSION [MM]
		STRANDED WIRE	SOLID WIRE						d ^{+0,1} x l _{min}
ETM-4		4.0	6.0	Ø 2.8	6.5	11.2	Ø 7.15	M+ST	Ø 6.8 x 7
ETN-4		4.0	6.0	Ø 2.8	6.5	11.2	Ø 7.15	N	Ø 6.8 x 7
PTM-1.5		1.5	2.5	Ø 1.8	5.5	8.7	Ø 5.15	M+ST	Ø 4.9 x 6
PTM-4		4.0	6.0	Ø 2.8	6.5	11.2	Ø 7.15	M+ST	Ø 6.8 x 7
PTN-1.5		1.5	2.5	Ø 1.8	5.5	8.7	Ø 5.15	N	Ø 4.9 x 6

Ordering: Earth Terminal **ETM-4**
Protection Terminal **PTM-1.5**

STOPPING PLUS FLAMEPROOF/EXPLOSIONPROOF EExde/XD			
TYPE OF ENCLOSURE	DRAFT	THREAD D ₁	ORDERING No.
XD-AD..		M20x1.5	SP-AD-M20
		G½B	SP-AD-G2
		G¾B	SP-AD-G3
The rest of all types of enclosures		M20x1.5 - 6g	SP-M20
		M25x1.5 - 6g	SP-M25
		G½B	SP-G2
		G¾B	SP-G3
		½NPT	SP-N2
		¾NPT	SP-N3

ACCESSORIES FOR CONNECTION HEADS

11