

## CONNECTION HEAD - type XE-DANAF

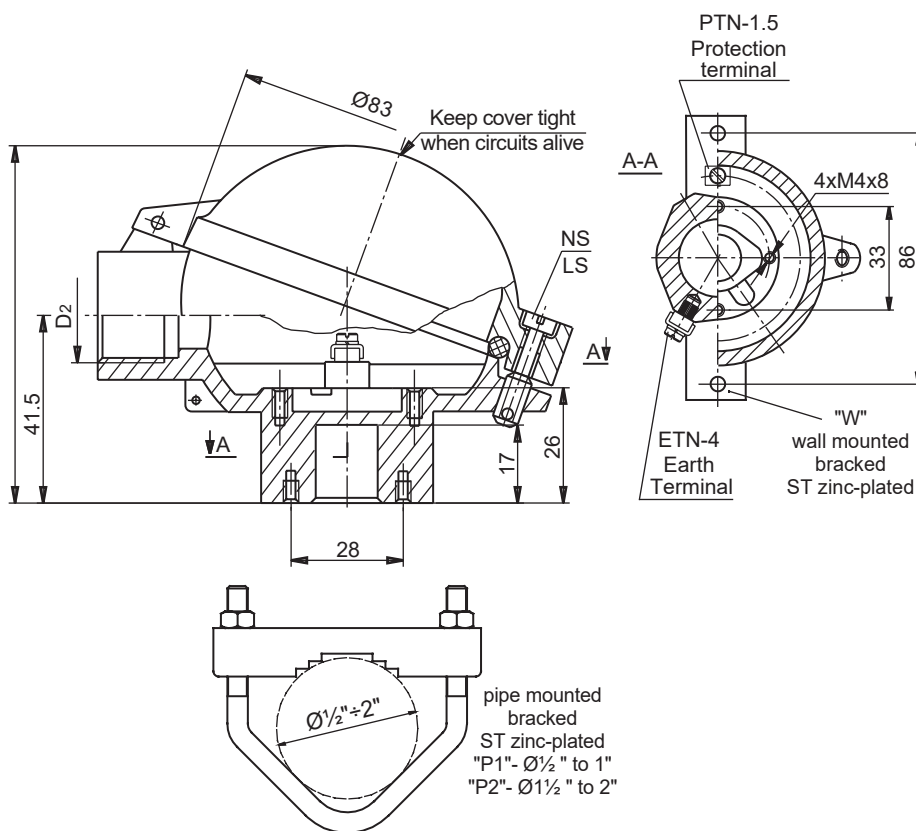

II 2G Ex eb IIC Gb

II 2D Ex tb IIIC Db  
FTZU 03 ATEX 0073U

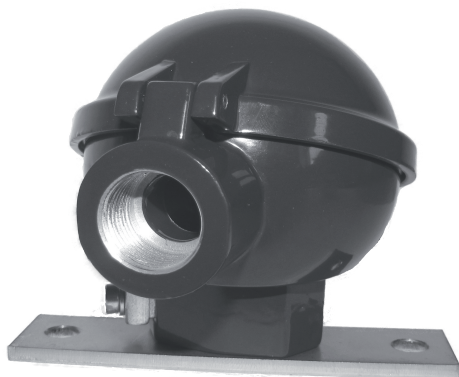
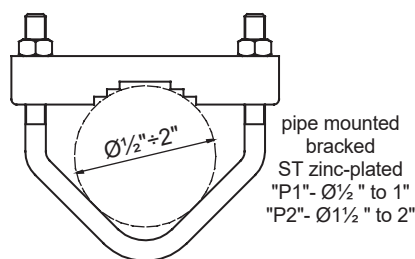

pipe mounted  
bracketed  
ST zinc-plated  
"P1"- Ø1/2 " to 1"  
"P2"- Ø1/2 " to 2"

EX HEADS

06

(1)	XE-DANAF	ORDERING CODE	SPECIFICATION
(2)	Material of elements	3	other metal parts - stainless steel; seals-oil resistant rubber (-40...100°C)
(3)	Cable gland thread	M2	M20x1.5
		N2	1/2NPT (empty thread only)
(7)	Cover closure	NS	Screws without leaden seal holes
		LS	Screws with leaden seal holes
(8)	Paint type	P	Polyester
		E	Epoxy
		C	Creodur - Rafil
		SE	Spray epoxy
		SPU	Spray polyurethane on (SE) layer
(9)	Paint colour	al	alu natural colour (only Creodur - Rafil)
		yc	RAL 1007 daffodil yellow
		ys	RAL 1003 signal yellow
		bs	RAL 5005 signal blue
		sb	RAL 5015 sky blue
		sg	RAL 7032 pebble grey
		gr	RAL 7035 light grey
		ag	RAL 9002 grey white
		sh	RAL 9006 white aluminium
		gs	RAL 9007 grey aluminium
		cw	RAL 9010 pure white
wa	white aluminium (substitute of Cal, only Polyester)		
(10)	Bracket type	W	Fixing on a wall
		P	Fixing on a pipe
		X	Without bracket

### Main features:

- material of body and cover - aluminium pressure die-castings, max 0.5%Mg
- service temperature:  $T_{serv} = -40+100^{\circ}\text{C}$
- maximum space for transmitter:  $\text{Ø}45 \times 40\text{mm}$

### Ordering example:

(1) (2) (3) (7) (8) (9) (10)  
XE-DANAF 3 - M2 - NS - P sh + W