

29.01.2018r.

APPLICATION MANUAL

Connection head for intrinsic safety apparatus – gas atmosphere
ATMOSFERY GAZOWE

Type : XI-DSNW (NS/LS, SL)



Contents:

1. Destination.
2. Process openings: D1, d1.
3. Conduit opening: D2.
4. Maximum space for transmitter.
5. Warning phrase.
6. Protection degree.
7. Marking.

Page 1 of 5



Datum: 22. 02. 2018

Podpis: *Florian*

1. Destination.

Connection head Xi – DSNW are foreseen to accommodate both:
 DIN – measuring insert and temperature transmitter of temperature sensor.
 Both of them are destined for use in hazardous areas :

- surface equipment (non mining) II
- equipment category 1
- type of flammable substance G

- Type of protection Ex ia II C
- Marking to 2014/34/UE II 1 G
- Standards : ATEX 2014/34/UE
 EN 60079 - 0
 EN 60079 - 11

Material of body, cover and press cap. PAV –PA-12 antistatic black
 (Vestamid L-R2-GF25)

Increased safety XI – DSNW connection head

Equipment protection by intrinsic safety „i” (IEC EN 60079 - 0 ; 60079 - 11)

Service temperature

Connection head type	T serv
XI – DSNW	- 40 to 100 ° C

Possible zone application



Datum: 22. 02. 2018

Podpis: *Flora*

Zone	Protection Code
Zone 0, Zone 1, Zone 2	Ex ia

2. Process openings: D1, d1.

Dimension of thread D₁ for sensor for thermowells and hole d₁ are given in the table below.

3. Conduit opening: D2.

Connection head is adopted to be equipped with certificated Ex i: cable glands, sealing fittings or flexible couplings.

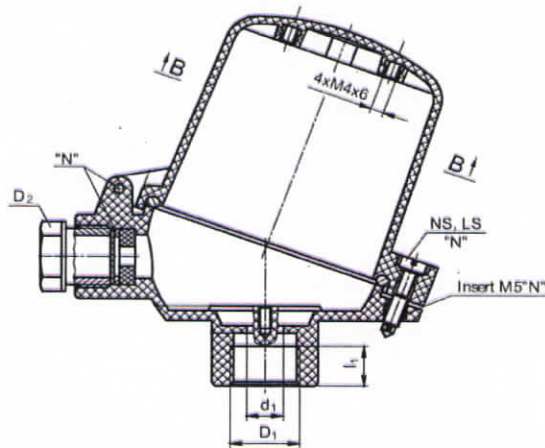

XI-DSNW (NS/LS)

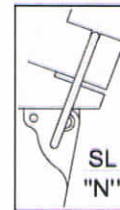

XI-DSNWSL (Snap Lock)

Cable gland		Body		Closure	Material	
D2 (mm)	d2 (mm)	D1 (mm)	d1 (mm)	Type	Material of screw; SL	Material of seal
M20x1,5	14	M20x1,5	11	NS	1.4541	Tefabloc TO 421
G1/2	14	M24x1,5	11	LS	wg	53A
Pg16	14	G1/2	11	SL (Snap Lock)	N-EN 10088-1	Elastosil R401
1/2NPT	-	1/2NPT	-			

4. Maximum space for transmitter.

Connection head housing type	At the body	In the cover
XI-DSNW	ø 45x16	ø 60x40

Protection Method	Type of protection	ATEX 2014/34/UE	Permitted use	Protection Principle
Intrinsic safety EN 60079 - 0 EN 60079 - 11	Ex ia IIC	II 1G	Zone 0, Zone 1, Zone 2	Limit energy of sparks and surface temperature

5. Warning phrase.

Connection head housing	Warning phrase on	Type of circuits permitted enclosed inside	Connection head housing equipped with additional
XI - DSNW	Yes	intrinsically safe	non required

6. Protection degree.

There are three places which decide of IP degree .

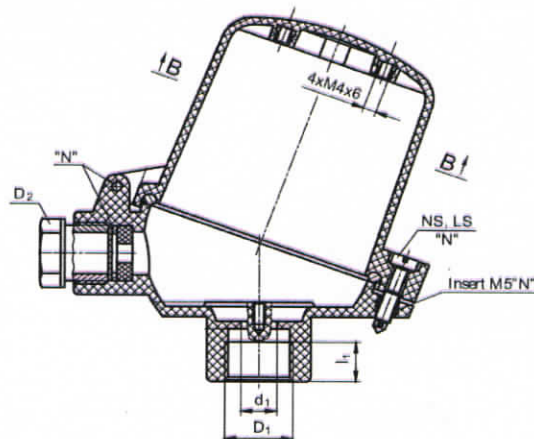

LIMATHERM COMPONENTS RESPONSIBILITY:

- sealing surface quality
- design
- execution quality

7. Marking.

According to standards:

- ATEX 2014/34/UE
- EN 60079 - 0
- EN 60079 - 11

Marking of the XI – DSNW is as follow:

LIMATHERM COMPONENTS POLAND
ŻELAZNA 5, 41-506 CHORZÓW
1026 Ex II 1G Ex ia IIC Ga
FTZU 12 ATEX 0202 U
Type: XI-DSNW

Batch number

ZP/

Each connection head is equipped with this label. The label is put inside.
Sensor producer should apply own label with the rest marking of complete sensor or transfer valuable information from Limatherm Components Sp. z o.o. label to sensor label.
To each batch of connection heads will be attached also this **Application Manual** with drawing of the marking label.

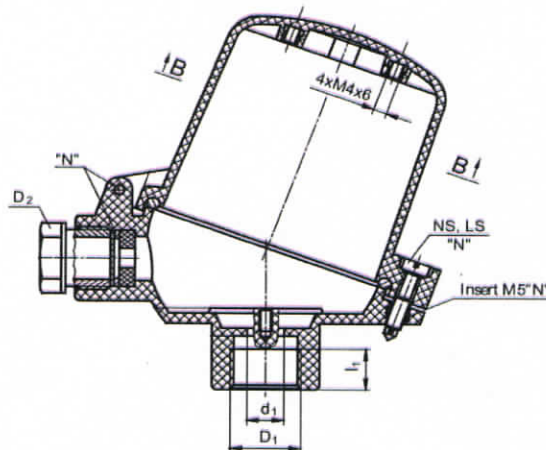

Plastic product label – glued