

CONNECTION HEAD - type XE-DANA

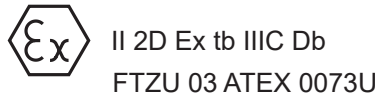
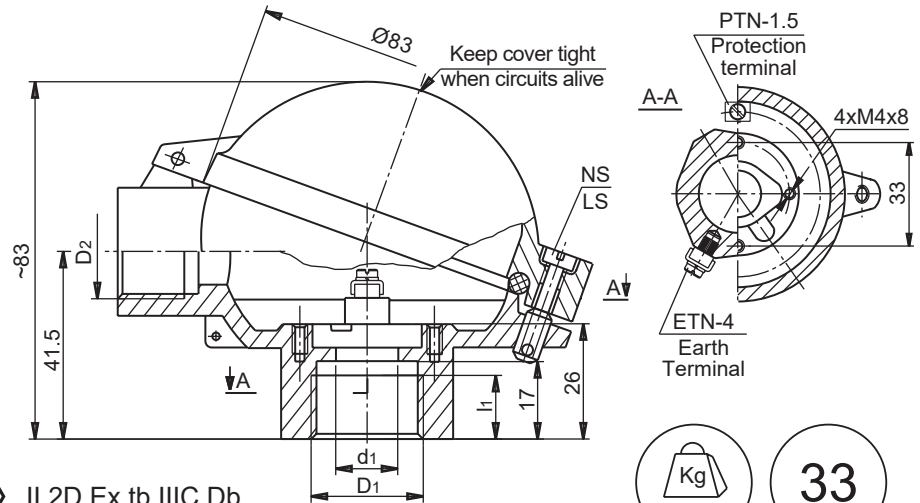

EX HEADS

06

(1)	XE-DANA	ORDERING CODE	SPECIFICATION		
(2)	Material of elements	3	other metal parts - stainless steel; seals-oil resistant rubber (-40...100°C)		
(3)	Cable gland thread	M2	M20x1.5		
		N2	½NPT (empty thread only)		
(5)	Type of process thread D ₁ /d ₁		D₁[ø]	d₁[ø]	l₁
		5	M24x1.5	Ø14	17
		6	G¾	Ø11	17
		7	G½	Ø11	17
		8	G¾	Ø14	17
		13	M20x1.5	Ø14	17
(7)	Cover closure	NS	Screws without leaden seal holes		
		LS	Screws with leaden seal holes		
(8)	Paint type	P	Polyester		
		E	Epoxy		
		C	Creodur - Rafil		
		SE	Spray epoxy		
		SPU	Spray polyurethane on (SE) layer		
(9)	Paint colour	al	alu natural colour (only Creodur - Rafil)		
		yc	RAL 1007 daffodil yellow		
		ys	RAL 1003 signal yellow		
		bs	RAL 5005 signal blue		
		sb	RAL 5015 sky blue		
		sg	RAL 7032 pebble grey		
		gr	RAL 7035 light grey		
		ag	RAL 9002 grey white		
		sh	RAL 9006 white aluminium		
		gs	RAL 9007 grey aluminium		
wa	white aluminium (substitute of Cal, only Polyester)				

Main features:

- material of body and cover - aluminium pressure die-castings, max 0.5%Mg
- service temperature: T_{serv} = -40÷100°C
- maximum space for transmitter: Ø45x40mm

Ordering example:

(1) XE-DANA (2) 3 (3) M2 (5) 5 (7) NS (8) P (9) sh